

# Complete Speed of Light Apparatus

OS-9261B

## Basic Speed of Light Apparatus

OS-9262A

## High Speed Rotating Mirror

OS-9263B

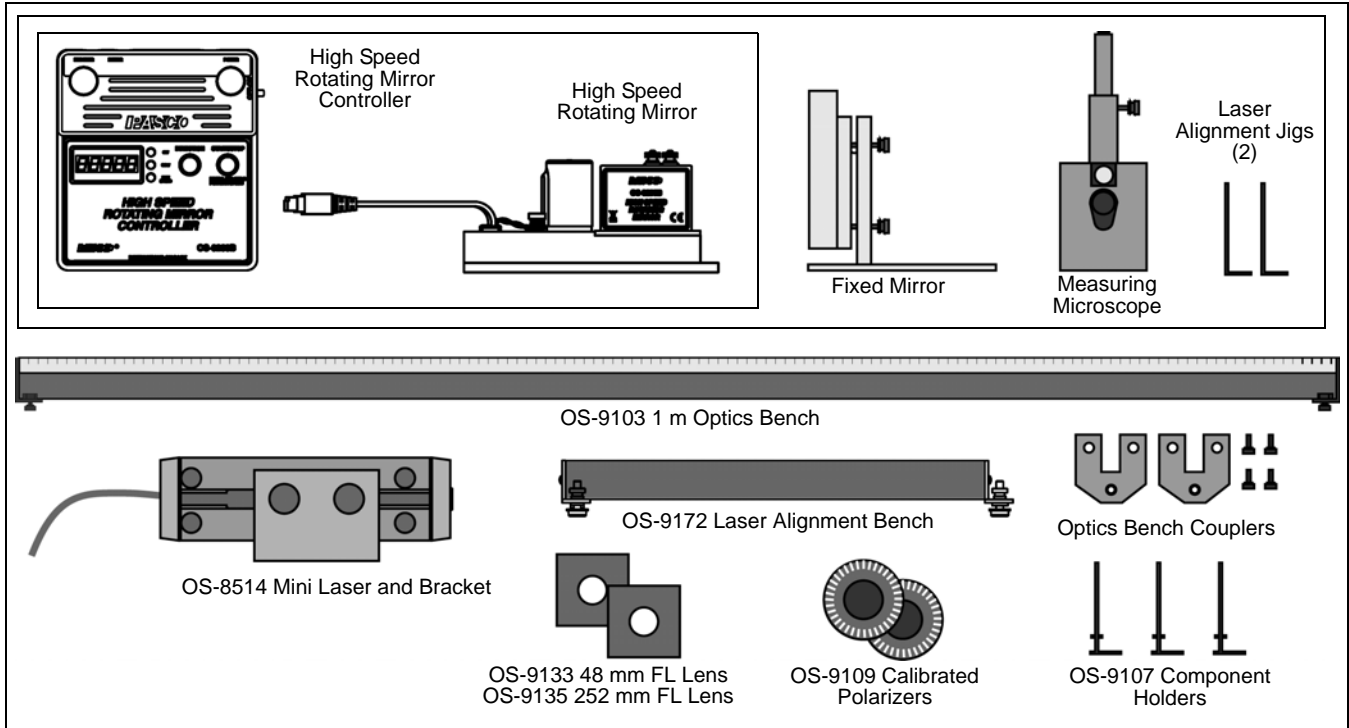

Model	Included Items
OS-9263B	High Speed Rotating Mirror Controller
	High Speed Rotating Mirror

Model	Included Items
OS-9262A	OS-9263B
	Fixed Mirror
	Measuring Microscope
	Laser Alignment Jigs (2)

Model	Included Items
OS-9261B	OS-9262A and OS-9263B
	OS-9103 1 m Optics Bench
	OS-8514 Mini Laser and Bracket
	OS-9172 Laser Alignment Bench*
	OS-9133 48 mm FL Lens
	OS-9135 252 mm FL Lens
	OS-9109 Calibrated Polarizers (2)
OS-9107 Component Holders (3)	

\*The OS-9172 Laser Alignment Bench includes two Optics Bench Couplers with screws.

## Introduction

The velocity of light in free space is one of the most important and intriguing constants of nature. Whether the light comes from a laser on a desk top or from a star that is hurtling away at fantastic speeds, if you measure the velocity of the light, you measure the same constant value. In more precise terminology, the velocity of light is independent of the relative velocities of the light source and the observer.

Furthermore, as Einstein first presented in his Special Theory of Relativity, the speed of light is critically important in some surprising ways. In particular:

1. The velocity of light establishes an upper limit to the velocity that may be imparted to any object.
2. Objects moving near the velocity of light follow a set of physical laws drastically different, not only from Newton's Laws, but from the basic assumptions of human intuition.

With this in mind, it's not surprising that a great deal of time and effort has been invested in measuring the speed of light. Some of the most accurate measurements were made by Albert Michelson between 1926 and 1929 using methods very similar to those you will be using with the PASCO Speed of Light Apparatus. Michelson measured the velocity of light in air to be  $2.99712 \times 10^8$  m/s. From this result he deduced the velocity in free space to be  $2.99796 \times 10^8$  m/s.

But Michelson was by no means the first to concern himself with this measurement. His work was built on a history of ever-improving methodology.

### Measuring the Speed of Light: History

#### Galileo

Through much of history, those few who thought to speculate on the velocity of light considered it to be infinite. One of the first to question this assumption was the great Italian physicist Galileo Galilei, who suggested a method for actually measuring the speed of light.

The method was simple. Two people, call them A and B, take covered lanterns to the tops of hills that are separated by a distance of about a mile. First A uncovers her lantern. As soon as B sees A's light, she uncovers her own lantern. By measuring the time from when A uncovers her lantern until A sees B's light, then dividing this time by twice the distance between the hill tops, the speed of light can be determined.

However, the speed of light being what it is, and human reaction times being what they are, Galileo was able to determine only that the speed of light was far greater than could be measured using his procedure. Although Galileo was unable to provide even an approximate value for the speed of light, his experiment set the stage for later attempts. It also introduced an important point: to measure great velocities accurately, the measurements must be made over a long distance.

#### Römer

The first successful measurement of the velocity of light was provided by the Danish astronomer Olaf Römer in 1675.

Römer based his measurement on observations of the eclipses of one of the moons of Jupiter. As this moon orbits Jupiter, there is a period of time when Jupiter lies between it and the Earth, and blocks it from view. Römer noticed that the duration of these eclipses was shorter when the Earth was moving toward Jupiter than when the Earth was moving away. He correctly interpreted this phenomena as resulting from the finite speed of light.

Geometrically the moon is always behind Jupiter for the same period of time during each eclipse. Suppose, however, that the Earth is moving away from Jupiter. An astronomer on Earth catches his last glimpse of the moon, not at the instant the moon moves behind Jupiter, but only after the last bit of unblocked light from the moon reaches his eyes. There is a similar delay as the moon moves out from behind Jupiter but, since the Earth has moved farther away, the light must now travel a longer distance to reach the astronomer. The astronomer therefore sees an eclipse that lasts longer than the actual geometrical eclipse. Similarly, when the Earth is moving toward Jupiter, the astronomer sees an eclipse that lasts a shorter interval of time.

From observations of these eclipses over many years, Römer calculated the speed of light to be  $2.1 \times 10^8$  m/s. This value is approximately one-third too slow due to an inaccurate knowledge at that time of the distances involved. Nevertheless, Römer's method provided clear evidence that the velocity of light was not infinite, and gave a reasonable estimate of its true value—not bad for 1675.

#### Fizeau

The French scientist Armand Hippolyte Fizeau, in 1849, developed an ingenious method for measuring the speed of light over terrestrial distances. He used a rapidly revolving cogwheel in front of a light source to deliver the light to a distant mirror in discrete pulses. The mirror reflected these pulses back toward the cogwheel. Depending on the position of the cogwheel when a pulse returned, it would either block the pulse of light or pass it through to an observer.

Fizeau measured the rates of cogwheel rotation that allowed observation of the returning pulses for carefully measured distances between the cogwheel and the mirror. Using this method, Fizeau measured the speed of light to be  $3.15 \times 10^8$  m/s. This is within a few percent of the currently accepted value.

#### Foucault

Léon Foucault improved Fizeau's method, using a rotating mirror instead of a rotating cogwheel. (Since this is the method you will use in this experiment, the details will be discussed in considerable detail in the next section.) As mentioned, Michelson used Foucault's method to produce some remarkably accurate measurements of the velocity of light. The best of these measurements gave a velocity of  $2.99774 \times 10^8$  m/s. This may be compared to the presently accepted value of  $2.99792458 \times 10^8$  m/s.

## The Foucault Method

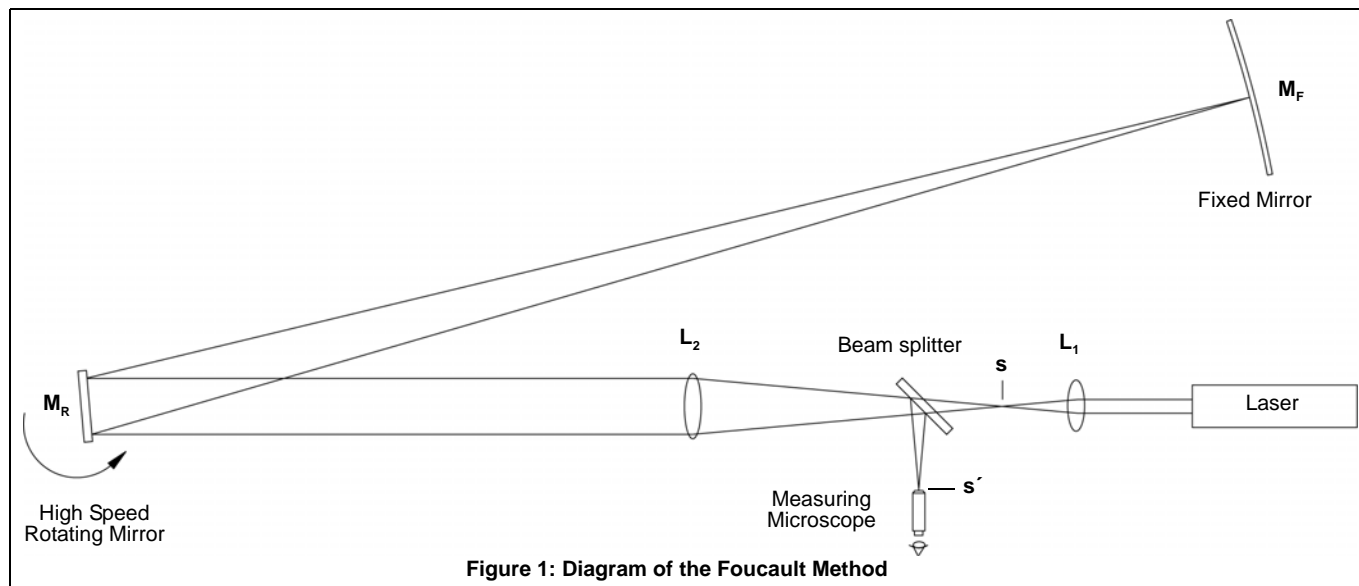

### A Qualitative Description

In this experiment, you will use a method for measuring the speed of light that is basically the same as that developed by Foucault in 1862. A diagram of the experimental setup is shown in Figure 1, above.

With all the equipment properly aligned and with the rotating mirror stationary, the optical path is as follows. The parallel beam of light from the laser is focused to a point image at point  $s$  by lens  $L_1$ . Lens  $L_2$  is positioned so that the image point at  $s$  is reflected from the rotating mirror  $M_R$ , and is focused onto the fixed, spherical mirror  $M_F$ . The fixed mirror,  $M_F$ , reflects the light back along the same path to again focus the image at point  $s$ .

In order that the reflected point image can be viewed through the measuring microscope, a beam splitter is placed in the optical path, so a reflected image of the returning light is also formed at point  $s'$ .

Now, suppose  $M_R$  is rotated slightly so that the reflected beam strikes  $M_F$  at a different point. Because of the spherical shape of  $M_F$ , the beam will still be reflected directly back toward  $M_R$ . The return image of the source point will still be formed at points  $s$  and  $s'$ . The only significant difference in rotating  $M_R$  by a slight amount is that the point of reflection on  $M_F$  changes.

Now imagine that  $M_R$  is rotating continuously at a very high speed. In this case, the return image of the source point will no longer be formed at points  $s$  and  $s'$ . This is because, with  $M_R$  rotating, a light pulse that travels from  $M_R$  to  $M_F$  and back finds  $M_R$  at a different angle when it returns than when it was first reflected. As will be shown in the following derivation, by measuring the displacement of the image point caused by the rotation of  $M_R$ , the velocity of light can be determined.

### A Quantitative Description

In order to use the Foucault method to measure the speed of light, it's necessary to determine a precise relationship between the speed of light and the displacement of the image point. Of course, other variables of the experimental setup also affect the displacement. These include:

- the rate of rotation of  $M_R$
- the distance between  $M_R$  and  $M_F$
- the magnification of  $L_2$ , which depends on the focal length of  $L_2$  and also on the distances between  $L_2$ ,  $L_1$ , and  $M_F$ .

Each of these variables will show up in the final expression that is derived for the speed of light.

To begin the derivation, consider a beam of light leaving the laser. It follows the path described in the qualitative description above. That is, first the beam is focused to a point at  $s$ , then reflected from  $M_R$  to  $M_F$  and back to  $M_R$ . The beam then returns through the beam splitter, and is refocused to a point at point  $s'$ , where it can be viewed through the microscope. This beam of light is reflected from a particular point on  $M_F$ . As the first step in the derivation, we must determine how the point of reflection on  $M_F$  relates to the rotational angle of  $M_R$ .

Figure 2a shows the path of the beam of light, from the laser to  $M_F$ , when  $M_R$  is at an angle  $\theta$ . In this case, the angle of incidence of the light path as it strikes  $M_R$  is also  $\theta$  and, since the angle of incidence equals the angle of reflection, the angle between the incident and reflected rays is just  $2\theta$ . As shown in the diagram, the pulse of light strikes  $M_F$  at a point that we have labeled  $S$ .

Figure 2b shows the path of the pulse of light if it leaves the laser at a slightly later time, when  $M_R$  is at an angle  $\theta_1 = \theta + \Delta\theta$ . The angle of incidence is now equal to

$\theta_1 = \theta + \Delta\theta$ , so that the angle between the incident and reflected rays is just  $2\theta_1 = 2(\theta + \Delta\theta)$ . This time we label the point where the pulse strikes  $M_F$  as  $S_1$ . If we define  $D$  as the distance between  $M_F$  and  $M_R$ , then the distance between  $S$  and  $S_1$  can be calculated:

$$S_1 - S = D(2\theta_1 - 2\theta) = D[2(\theta + \Delta\theta) - 2\theta] = 2D\Delta\theta \text{ (EQ1)}$$

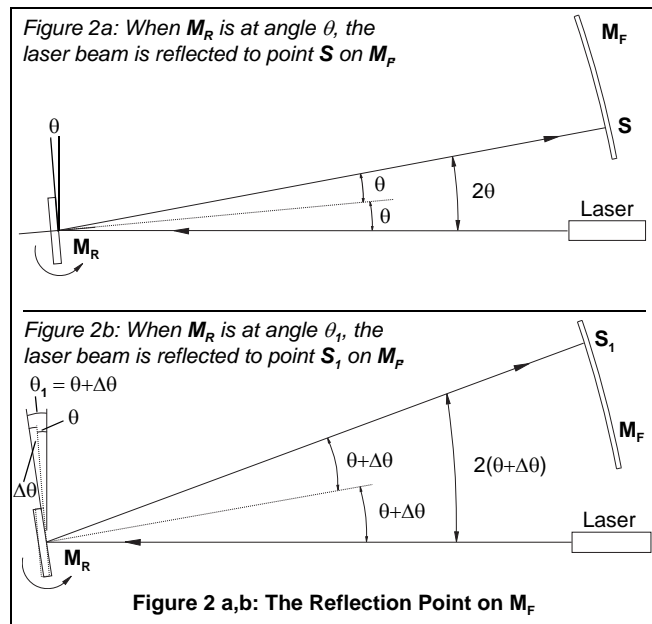

In the next step in the derivation, it is helpful to think of a single, very quick pulse of light leaving the laser. Suppose  $M_R$  is rotating, and this pulse of light strikes  $M_R$  when it is at angle  $\theta$ , as in Figure 2a. The pulse will then be reflected to point  $S$  on  $M_F$ . However, by the time the pulse returns to  $M_R$ ,  $M_R$  will have rotated to a new angle, say angle  $\theta_1$ . If  $M_R$  had not been rotating, but had remained stationary, this returning pulse of light would be refocused at point  $S$ . Clearly, since  $M_R$  is now in a different position, the light pulse will be refocused at a different point. We must now determine where that new point will be.

The situation is very much like that shown in Figure 2b, with one important difference: the beam of light that is returning to  $M_R$  is coming from point  $S$  on  $M_F$ , instead of from point  $S_1$ . To make the situation simpler, it is convenient to remove the confusion of the rotating mirror and the beam splitter by looking at the virtual images of the beam path, as shown in Figure 3.

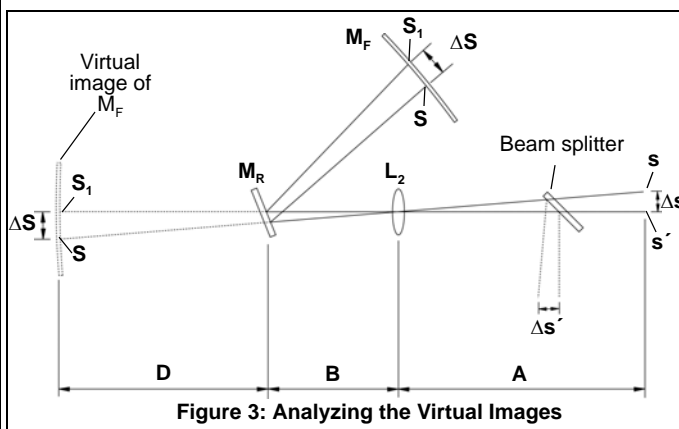

The critical geometry of the virtual images is the same as for the reflected images. Looking at the virtual images, the problem becomes a simple application of thin lens optics. With  $M_R$  at angle  $\theta_1$ , point  $S_1$  is on the focal axis of lens  $L_2$ . Point  $S$  is in the focal plane of lens  $L_2$ , but it is a distance  $\Delta S = S_1 - S$  away from the focal axis. From thin lens theory, we know that an object of height  $\Delta S$  in the focal plane of  $L_2$  will be focused in the plane of point  $s$  with a height of  $(-i/o)\Delta S$ . Here  $i$  and  $o$  are the distances of the lens from the image and object, respectively, and the minus sign corresponds to the inversion of the image. As shown in Figure 3, reflection from the beam splitter forms a similar image of the same height.

Therefore, ignoring the minus sign since we aren't concerned that the image is inverted, we can write an expression for the displacement ( $\Delta s'$ ) of the image point:

$$\Delta s' = \Delta s = \left(\frac{i}{o}\right)\Delta S = \frac{A}{D+B}\Delta S \text{ (EQ2)}$$

Combining equations 1 and 2, and noting that  $\Delta S = S_1 - S$ , the displacement of the image point relates to the initial and secondary positions of  $M_R$  by the formula:

$$\Delta s' = \frac{2DA\Delta\theta}{D+B} \text{ (EQ3)}$$

The angle  $\Delta\theta$  depends on the rotational velocity of  $M_R$  and on the time it takes the light pulse to travel back and forth between the mirrors  $M_R$  and  $M_F$ , a distance of  $2D$ . The equation for this relationship is:

$$\Delta\theta = \frac{2D\omega}{c} \text{ (EQ4)}$$

where  $c$  is the speed of light and  $\omega$  is the rotational velocity of the mirror in radians per second. ( $2D/c$  is the time it takes the light pulse to travel from  $M_R$  to  $M_F$  and back.)

Using equation 4 to replace  $\Delta\theta$  in equation 3 gives:

$$\Delta s' = \frac{4AD^2\omega}{c(D+B)} \quad (\text{EQ5})$$

Equation 5 can be rearranged to provide our final equation for the speed of light:

$$c = \frac{4AD^2\omega}{(D+B)\Delta s'} \quad (\text{EQ6})$$

where:

$c$  = the speed of light

$\omega$  = the rotational velocity of the rotating mirror ( $M_R$ )

$A$  = the distance between lens  $L_2$  and lens  $L_1$ , minus the focal length of  $L_1$

$B$  = the distance between lens  $L_2$  and the rotating mirror ( $M_R$ )

$D$  = the distance between the rotating mirror ( $M_R$ ) and the fixed mirror ( $M_F$ )

$\Delta s'$  = the displacement of the image point, as viewed through the microscope. ( $\Delta s' = s_1 - s$ ; where  $s$  is the position of the image point when the rotating mirror ( $M_R$ ) is stationary, and  $s_1$  is the position of the image point when the rotating mirror is rotating with angular velocity  $\omega$ .)

Equation 6 was derived on the assumption that the image point is the result of a single, short pulse of light from the laser. But, looking back at equations 1 through 4, the displacement of the image point depends only on the difference in the angular position of  $M_R$  in the time it takes for the light to travel between the mirrors. The displacement does not depend on the specific mirror angles for any given pulse.

If we think of the continuous laser beam as a series of infinitely small pulses, the image due to each pulse will be displaced by the same amount. All these images displaced by the same amount will, of course, result in a single image. By measuring the displacement of this image, the rate of rotation of  $M_R$ , and the relevant distances between components, the speed of light can be measured.

## The Equipment

### What You Need to Measure the Speed of Light

As described previously, the OS-9263B High Speed Rotating Mirror includes the mirror and the High Speed Rotating Mirror Controller.

The OS-9262A Basic Speed of Light Apparatus includes the items in the OS-9263B plus the Fixed Mirror, the Measuring Microscope, and two Laser Alignment Jigs.

The OS-9261B Complete Speed of Light has the OS-9263B and the OS-9262A and adds the OS-9103 1 m Optics Bench, the OS-8514 Mini Laser and Bracket, the OS-9172 Laser Alignment Bench (with included Optics Bench Couplers), two convex lenses (OS-9133 48 mm FL and OS-9135 252 mm FL), two Calibrated Polarizers (OS-9109), and three Component Holders (OS-9107).

What else is needed? You need level surfaces for the optics bench setup and for the Fixed Mirror, and at least two meters of distance between the High Speed Rotating Mirror and the Fixed Mirror. A distance of 10 to 15 meters between the High Speed Rotating Mirror and the Fixed Mirror is preferred.

## About the Equipment

### High Speed Rotating Mirror

The High Speed Rotating Mirror connects to the High Speed Rotating Controller, which has a power supply and a digital display. The mirror is flat to within one-quarter wavelength. The mirror shaft is supported on high speed ball bearings and is mounted in a protective, removable housing. The mirror is driven by a small motor with a drive belt. A thumbscrew in the base can be used to hold the mirror in place during the alignment process. An optical decoder on the drive wheel and the digital display on the controller provide measurements of mirror rotation to within 0.1% or one revolution per second.

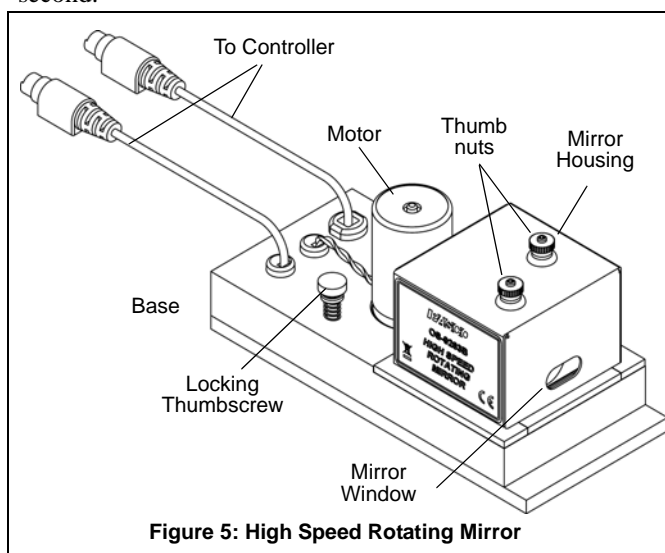

### High Speed Rotating Mirror Controller

The High Speed Rotating Mirror Controller has a digital display of the mirror's rotational speed in revolutions per second, a slide switch for OFF-ON, two control buttons (DIRECTION and START/STOP), two green light emitting diode (LED) indicators for direction of rotation (CW - clockwise - and CCW - counterclockwise), and a third yellow LED indicator for maximum speed (MAX SPEED).

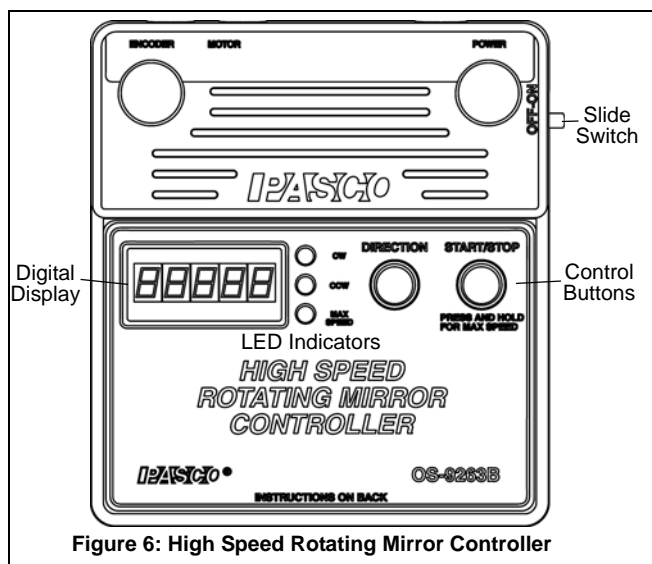

Figure 6: High Speed Rotating Mirror Controller

At the top end of the Controller are three ports for connecting the High Speed Rotating Mirror and the power supply for the controller.

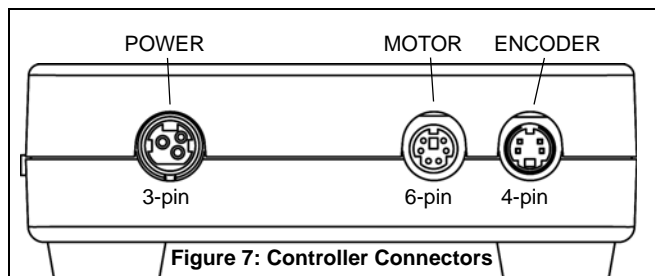

Figure 7: Controller Connectors

Each cable that plugs into the controller has a unique number of pins so that the cables cannot be connected incorrectly.

### Operating the Controller

The Controller can make the High Speed Rotating Mirror rotate in two directions and at two different speeds (750 rev/s and 1500 rev/s).

- When the slide switch is at the ON position, one of the direction indicator green LEDs will light up and begin to blink. The digital display will show “0” as the speed.
- Press the DIRECTION control button to switch to the other direction. The other green LED will blink.
- Press the START/STOP control button to cause the High Speed Rotating Mirror to begin rotating. The digital display will show “750” as the speed. The green direction indicator LED will continue to blink as the mirror speeds up, and then the LED will shine continuously when the mirror reaches the indicated speed.
- Press the START/STOP control button again to cause the mirror to stop rotating.
- To achieve the maximum speed, first press the START/STOP control button and let the mirror speed up to the “750” speed, as indicated by the green LED shining continuously. Then, press and HOLD the START/STOP button. The digital display will show

“1500”, the yellow ‘MAX SPEED’ LED will shine continuously, and the green direction indicator LED will blink until the mirror reaches the indicated speed.

- When the green LED shines continuously, release the START/STOP button. The mirror will continue to rotate at the maximum speed until you press the START/STOP button again to stop the rotation.
- **WARNING:** The High Speed Rotating Mirror is designed to rotate at maximum speed for a limited time. When the yellow LED starts blinking, the controller is nearing automatic shutoff.
-  If all three LEDs are blinking, the motor current is too high and the controller will automatically shut down. There will be a ‘cool down’ time of about one minute before the unit can be used again.

**CAUTION:** Before turning on the High Speed Rotating Mirror Controller, carefully read the cautionary notes in the section titled *Making the Measurement*.

### Measuring Microscope

The Measuring Microscope has a 90 power (90X) microscope mounted in a microscope holder. The holder is mounted in a movable micrometer stage just underneath the top of the micrometer housing. The stage can be moved back-and-forth using the micrometer knob. Beneath the micrometer is a knob that is mounted on the shaft of the beam splitter. The beam splitter holds the half-silvered mirror that splits the laser beam. When the knob is straight down, the beam splitter mirror is at a forty-five degree angle.

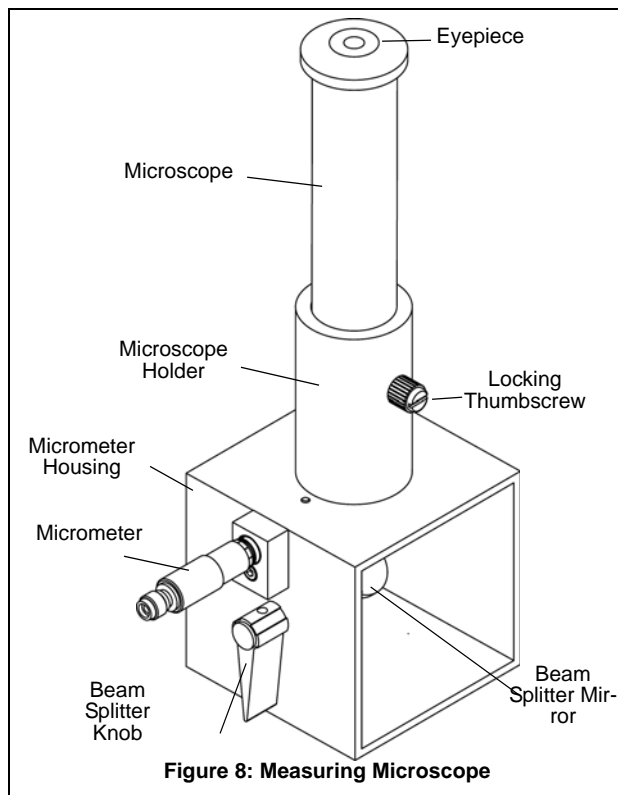

Figure 8: Measuring Microscope

Measurements are made by using the micrometer to move the microscope so that the image point is visually centered on the microscope cross-hairs before and after the displacement of the point that occurs when the rotating mirror reaches full speed. By noting the change in the micrometer settings, the displacement,  $\Delta s'$ , can be resolved to within 0.005 millimeters.

### Focusing

To focus the microscope cross-hairs, slide the eyepiece up or down in the microscope. To focus the microscope, loosen the locking thumbscrew on the microscope holder and slide the microscope up or down within the holder.

When the locking thumbscrew is loosened, the microscope can also be removed from the microscope holder. This can be helpful when you are trying to locate the image point. A piece of tissue paper placed other the opening of the microscope holder provides a screen that allows you to view the point without focusing the microscope.

### Fixed Mirror

The Fixed Mirror is a spherical mirror with a radius of curvature of 13.5 meters. It is mounted on a platform and has two separate x and y adjustment screws on the back.

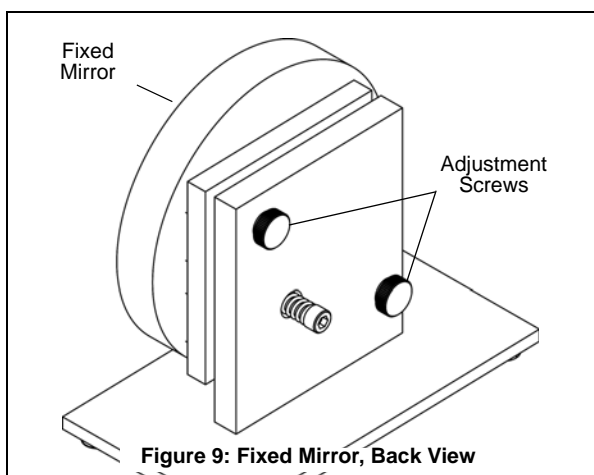
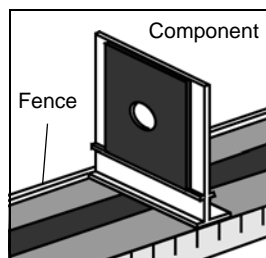

Figure 9: Fixed Mirror, Back View

### Optics Bench

The one meter Optics Bench provides a flat, level surface for aligning the optical components. The bench is equipped with a one meter scale on one side, four leveling screws, and a magnetic top surface. The “fence”, a raised edge on the back of the bench, provides a guide for aligning components along the optical axis.



### Mini Laser with Bracket and Laser Alignment Bench

The 0.5 milliwatt, TEM<sub>00</sub> mode, random polarization laser has an output wavelength of 632.8 nanometers. The Bracket

comes with hardware for mounting the mini laser. The Laser Alignment Bench attaches to the Optics Bench at one end for precise position of the laser. Optics Bench Couplers are included with the Laser Alignment Bench.

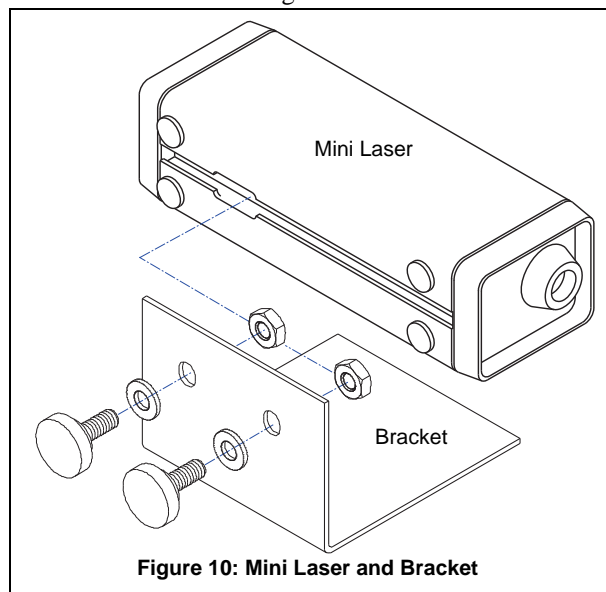

Figure 10: Mini Laser and Bracket

### Laser Alignment Jigs

The Laser Alignment Jigs mount magnetically to the Optics Bench. Each has a 2 mm diameter hole that is used to align the laser beam.

### Optical Components

The lenses, calibrated polarizers and component holders are described in the *Setup and Alignment* section of the manual.



## Setup and Alignment

The following setup and alignment procedure is designed for those using the Complete Speed of Light Apparatus. For those using only some of the components in the system, the general procedure is the same, although the details depend on the optical components used.

**IMPORTANT:** Proper alignment is critical, not only for getting good results, but for getting any results at all. Please follow this setup and alignment procedure carefully. Allow yourself about three hours to do it properly the first time. Once you have set up the equipment a few times, you may find that the alignment summary at the end of this section is a helpful guide.

For reference as you set up the equipment, Figure 11 shows the approximate positioning of the components with respect to the metric scale on the side of the Optics Bench. The exact placement of each component depends on the position of the Fixed Mirror ( $M_f$ ) and must be determined by following the steps of the alignment procedure described below.

All component holders, the Measuring Microscope, and the High Speed Rotating Mirror Assembly should be mounted flush against the “fence” of the Optics Bench. This will insure that all components are mounted at right angles to the beam axis.

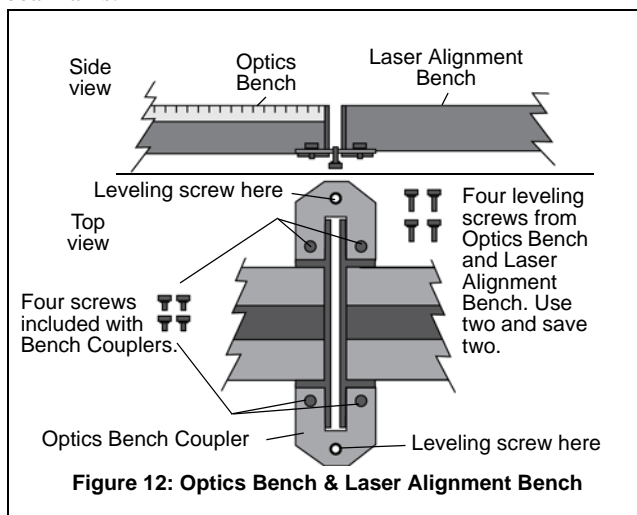

Figure 12: Optics Bench & Laser Alignment Bench

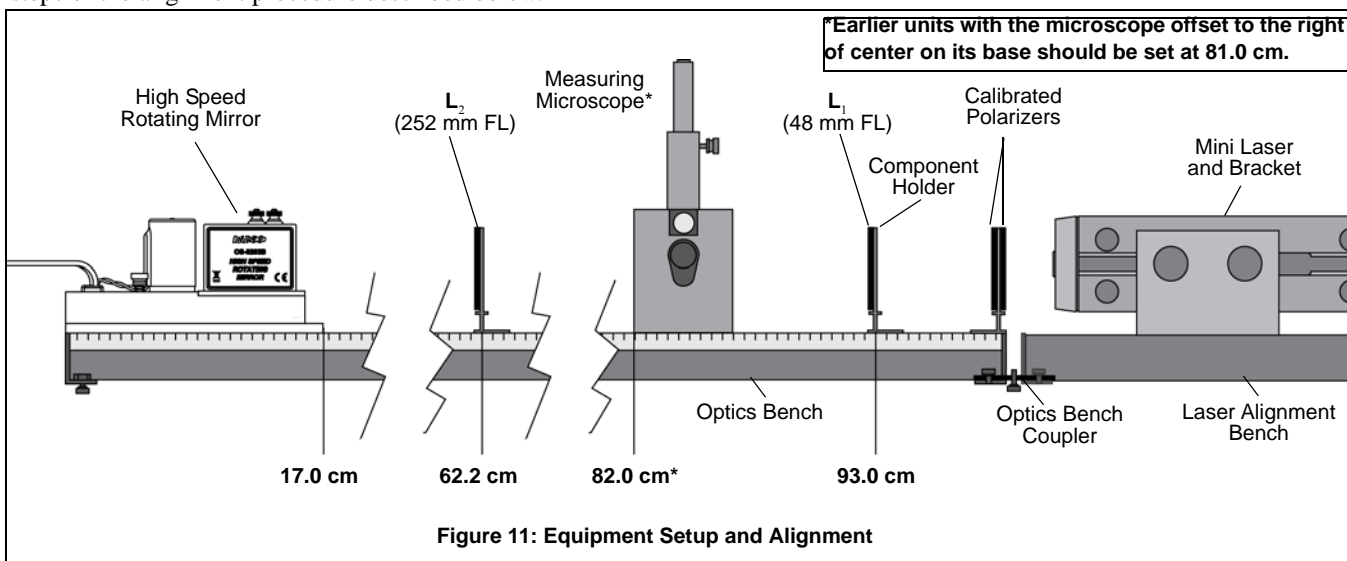

Figure 11: Equipment Setup and Alignment

### Set Up the Optics Bench and Laser Alignment Bench

1. Place the Optics Bench on a flat, level surface.
2. Use the Optics Bench Couplers and the provided screws to connect the Optics Bench end-to-end with the Laser Alignment Bench as shown in Figure 12. Do not tighten the screws holding the Bench Couplers yet.

**Note:** The leveling screws must be removed from the end of the Optics Bench and from the end of the Laser Alignment Bench to attach the Bench Couplers. Two of the removed leveling screws are then inserted into the threaded holes in the Bench Couplers and are used for leveling (see Figure 12). Save the other two screws/

3. Mount the Mini Laser on its bracket and place the bracket and laser on the Laser Alignment Bench.

### Laser Alignment Jigs

4. Mount the High Speed Rotating Mirror on the opposite end of the bench from the laser. Be sure that the base of the mirror assembly is flush against the fence of the bench.
5. Align the front edge of the mirror assembly with the 17 cm mark on the metric scale of the Optics Bench.



- The laser must be aligned so that the beam strikes the center of the Rotating Mirror ( $M_R$ ). Two alignment jigs are provided for this purpose.

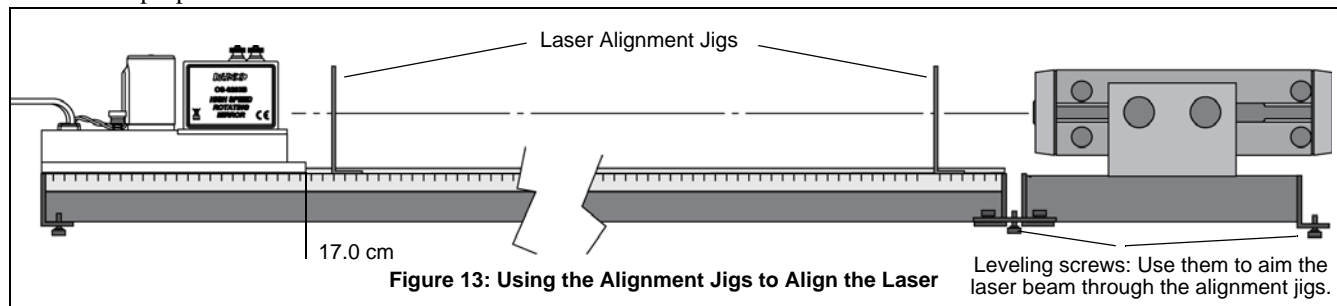

- Place one jig at each end of the Optics Bench as shown in Figure 13, with the edges of the jigs flush with the fence on the bench.
- When properly placed, the holes in the jigs define a straight line that is parallel to the axis of the Optics Bench.
- Turn on the laser.
- Adjust the position of the front of the laser so the beam passes directly through the hole in the first alignment jig.
- Use the two front leveling screws to adjust the height. Adjust the position of the laser on the Laser Alignment Bench to adjust the lateral position.
- Next, adjust the height and position of the rear of the laser so the beam passes directly through the hole in the second alignment jig.
- To fix the laser in position with respect to the Optics Bench, tighten the screws on the Optics Bench Couplers. Be sure to recheck the alignment of the laser beam and adjust if necessary.

**CAUTION:** Do not look into the laser beam, either directly or as it reflects from any surfaces. Also, when arranging the equipment, be sure that the beam does not cross an area where someone might accidentally look into the beam.

### Align the Rotating Mirror

The Rotating Mirror,  $M_R$ , must be aligned so that its axis of rotation is vertical and also perpendicular to the laser beam. In other words, the mirror surface will be at right angles to the laser beam.

- The Rotating Mirror assembly is covered by a mirror housing that is held in place by two thumb nuts (see Figure 5).
- Unscrew and remove the two thumb nuts on the top of the mirror housing. Carefully remove the mirror housing.

- The Rotating Mirror is driven by a high speed belt that goes around a pulley mounted underneath the motor. To the left of the Rotating Mirror assembly is an oblong slot. An edge of the pulley can be seen by looking down through the oblong slot. The slot provides access for you to rotate the pulley and thereby align the Rotating Mirror.

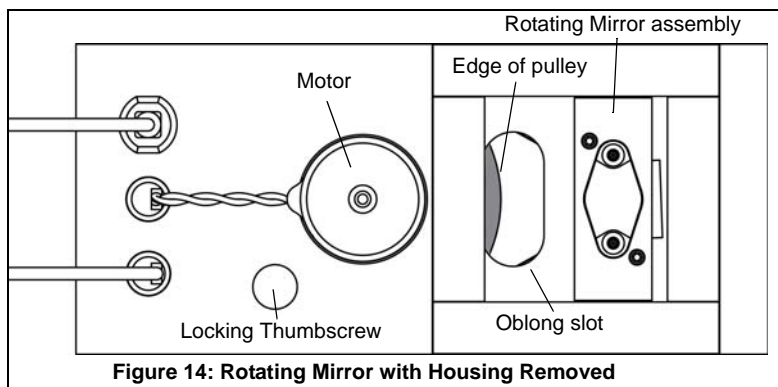

- Remove the second laser alignment jig (closest to the Rotating Mirror). Use a finger to rotate the pulley and turn the mirror so that the laser beam reflects from the surface of the Rotating Mirror back through the hole in the first alignment jig.

- Carefully tighten the locking thumbscrew so that it holds the pulley in place.

- CAUTION:** Do not over-tighten the thumbscrew in order to avoid warping the pulley.

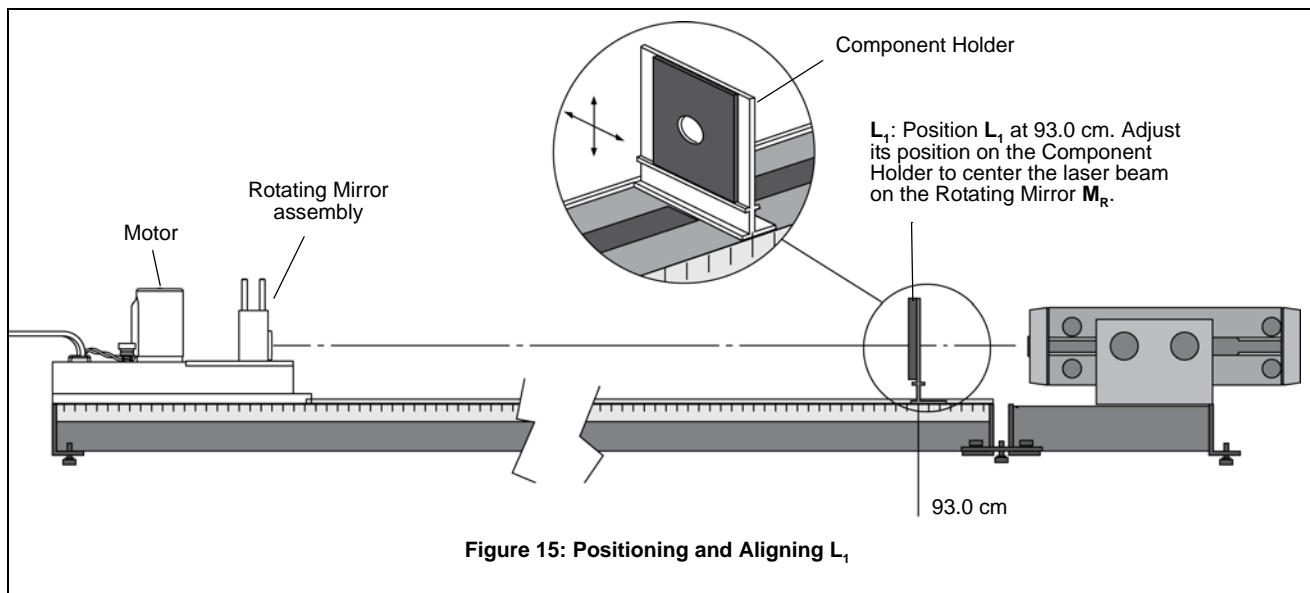
Figure 15: Positioning and Aligning  $L_1$ 

## Adding the Lenses

13. Remove the first laser alignment jig.
14. Mount the 48 mm focal length lens ( $L_1$ ) on one of the Component Holders. Place the Component Holder on the Optics Bench so that the center line of the holder is aligned with the 93.0 cm mark on the metric scale of the bench.
15. Without letting the Component Holder move, slide  $L_1$  up, down, or sideways as needed to center the laser beam on the surface of the Rotating Mirror ( $M_R$ ).
  - NOTE: The lens will spread the laser beam slightly at the position of the Rotating Mirror
16. Mount the f252 mm focal length lens ( $L_2$ ) on a second Component Holder. Place the Component Holder on the Optics Bench so that the center line of the holder is aligned with the 62.2 cm mark on the metric scale.
17. As for  $L_1$ , hold the Component Holder and adjust  $L_2$  up, down, or sideways as needed to center the laser beam again on the surface of the Rotating Mirror,  $M_R$ .

## Place the Measuring Microscope

18. Mount the Measuring Microscope on the Optics Bench so that the edge of the Microscope Housing is flush with the fence on the bench. Position the Measuring Microscope so that its left edge is aligned with the 82.0 cm mark on the metric scale on the bench (see Figure 11).
  - The side of the Microscope Housing with the Micrometer and the Beam Splitter Knob should be on the same side as the metric scale of the Optics Bench.
19. Position the Beam Splitter Knob so that it points directly down

**CAUTION:** Do not look through the Measuring Microscope until the polarizers have been placed between the laser and the beam splitter mirror in a later step.

- The beam splitter will slightly alter the position of the laser beam.
20. Readjust lens  $L_2$  on its Component Holder so that the laser beam is again centered on the Rotating Mirror,  $M_R$ .

## Position the Fixed Mirror

21. Place the Fixed Mirror ( $M_F$ ) between 2 and 15 meters from the Rotating Mirror ( $M_R$ ) as shown in Figure 16. The angle between the axis of the Optics Bench and a line from  $M_R$  to  $M_F$  should be approximately 12 degrees.
  - NOTE: If the angle between the axis of the Optics Bench and the line between the mirrors is greater than 20 degrees, the reflected beam will be blocked by the Rotating Mirror enclosure.
22. Make sure that the Fixed Mirror is not on the same side of the Optics Bench as the Micrometer so you will be able to make the measurements without blocking the laser beam.
  - NOTE: Best results are obtained when the Fixed Mirror ( $M_F$ ) is 10 to 15 meters from the Rotating Mirror ( $M_R$ ). See the *Notes on Accuracy* section later in the manual.

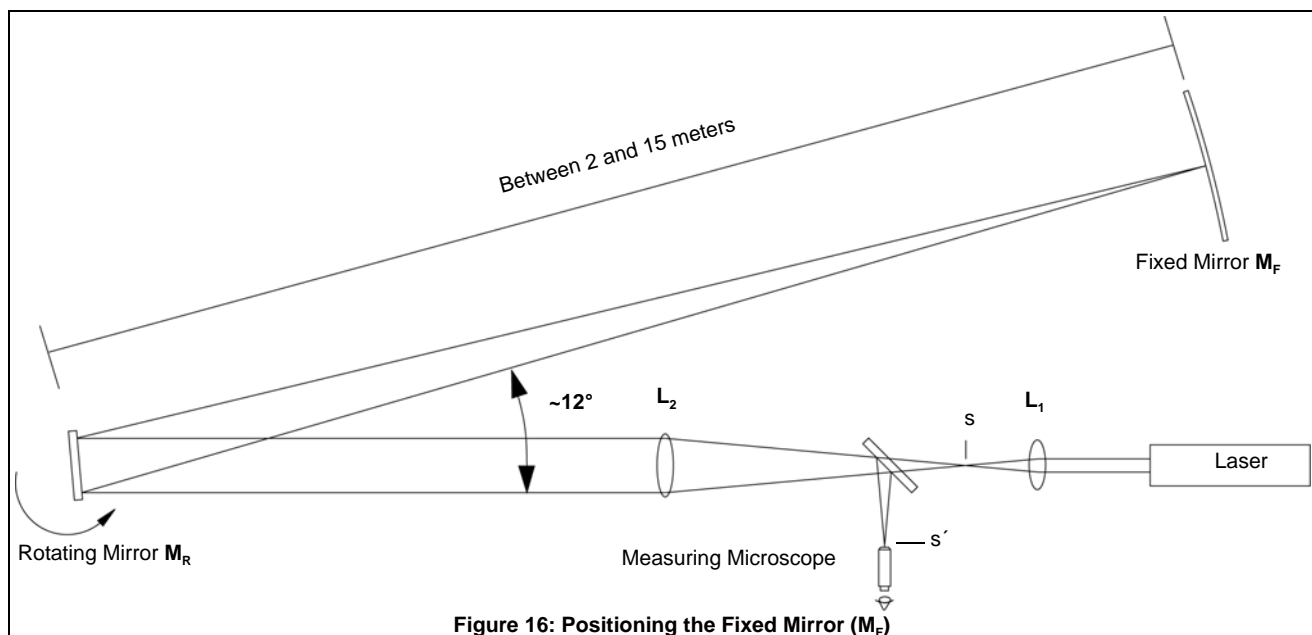

Figure 16: Positioning the Fixed Mirror ( $M_F$ )

23. Loosen the locking thumbscrew on the High Speed Rotating Mirror. Turn the rotating mirror  $M_R$  slightly so that the laser beam is reflected toward the fixed mirror  $M_F$ . Retighten the locking thumbscrew to hold  $M_R$  in place.
  - **NOTE:** Place a piece of paper in the beam path and “walk” the beam toward  $M_F$ , adjusting the rotation of  $M_R$  as needed.
24. Adjust the position of  $M_F$  so the beam strikes it approximately in the center. Again, a piece of paper in the beam path will make the beam easier to see.
25. With a piece of paper still against the surface of  $M_F$ , slide  $L_2$  back and forth along the Optics Bench to focus the beam to the smallest possible point on  $M_F$ .
26. Adjust the two thumbscrews on the back of  $M_F$  so that the beam is reflected directly back to the center of the Rotating Mirror,  $M_R$ . This step is best performed with two people: one adjusting  $M_F$ , and one watching the beam position on  $M_R$ .
27. Return the sound enclosure to the rotating mirror.

**Place the Polarizers on the Optics Bench**

28. Place a Calibrated Polarizer on each side of a Component Holder and mount the Component Holder with the two polarizers on the Optics Bench between the laser and  $L_1$ .
29. Begin with the polarizers at right angles to each other. While looking through the microscope, rotate one polarizer until the image is bright enough to view comfortably.

**NOTE: There are several things to try if you can't find the point image**

- Vary the tilt of the beam splitter slightly (no more than a few degrees) and turn the micrometer knob to vary the position of the microscope until the image comes into view.
- Loosen the lock-screw on the Microscope Holder and remove the Microscope temporarily as shown in Figure 17. Place a piece of tissue paper over the top of the Microscope Holder to locate the beam. Adjust the beam splitter angle and the micrometer knob to center the point image in the tube of the Microscope Holder.
- Slide the Measuring Microscope a centimeter or so in either direction along the axis of the Optics Bench. Be sure that the Measuring Microscope stays flush against the fence of the Optics Bench.

*If these steps don't work, recheck the alignment, beginning with step 1.*

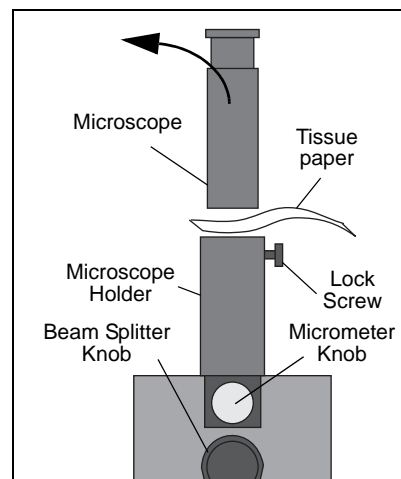

Figure 17: Looking for the Beam Image

## Focusing the Microscope

30. Bring the cross-hairs of the Microscope into focus by sliding the eyepiece up and down.
31. To focus the Microscope, loosen the lock screw on the Microscope Holder and slide the entire microscope up and down.
  - **NOTE:** If the apparatus is properly aligned, you will see the point image of the laser beam through the Microscope.
32. Focus the Microscope until the image is as sharp as possible.

**IMPORTANT:** In addition to the point image, you may also see interference fringes through the microscope resulting, for example, from reflection of the laser beam from  $L_1$ . To be sure that you are observing the correct point image, place an opaque piece of paper between  $M_R$  and  $M_F$  while you watch the point image in the Microscope. If the point image does not disappear, it is not the correct image.

## Cleaning Up the Image

In addition to the point image, you may also see interference fringes through the microscope (as well as the extraneous beam images mentioned above). These fringes cause no difficulty as long as the point image is clearly visible. However, the fringes and extraneous beam images can sometimes be removed without losing the point image.

33. Clean up the point image by turning  $L_2$  slightly askew, so it is no longer quite at a right angle to the beam axis (see Figure 18).

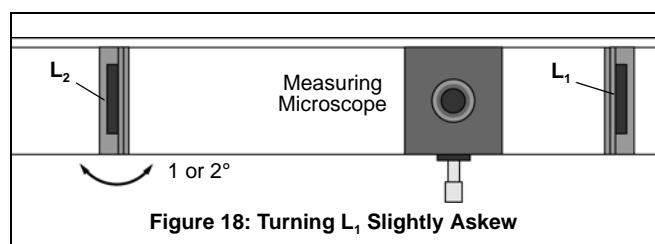

Figure 18: Turning  $L_1$  Slightly Askew

## Alignment Summary

(See Figure 11 for approximate component placement.)

This summary is for those who are familiar with the equipment and the experiment, and just need a quick reminder of the steps in the alignment procedure. If you have not successfully aligned the apparatus before, it is recommended that you take the time to go through the detailed procedure in the previous section.

1. Use the alignment jigs to align the laser beam so that it strikes the center of  $M_R$ .

2. Adjust the rotational axis of  $M_R$  so it is perpendicular to the beam (i.e., as  $M_R$  rotates, there must be a position at which it reflects the laser beam directly back to the laser aperture).
3. Insert  $L_1$  to focus the laser beam to a point. Adjust  $L_1$  so the beam is still centered on  $M_R$ .
4. Insert  $L_2$  and adjust it so the beam is still centered on  $M_R$ .
5. Place the Measuring Microscope in position and, again, be sure that the beam is still centered on  $M_R$ .

**CAUTION:** Do not look through the microscope until the polarizers are in place between the laser and the beam splitter.

6. Position  $M_F$  at the chosen distance from  $M_R$  (between 2 and 15 meters) so the reflected image from  $M_R$  strikes the center of  $M_F$ .
7. Adjust the position of  $L_1$  to focus the beam to a point on  $M_F$ .
8. Adjust  $M_F$  so the beam is reflected directly back onto  $M_R$ .
9. Insert the polarizers between the laser and the beam splitter.
10. Focus the microscope on the image point.
11. Remove the polarizers.

## Alignment Hints

Once you have the microscope focused, it may still be difficult to obtain a good image point. There may be several other lights visible in the microscope besides the image reflected from the fixed mirror.

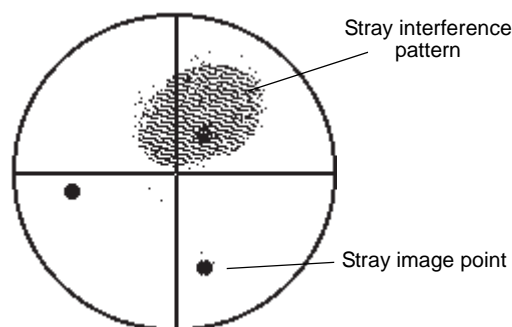

The most common of these are stray interference patterns. These are caused by multiple reflections from the surfaces of the lenses, and may be ignored. If necessary, you may be able to eliminate them by angling the lenses  $1 - 2^\circ$ .

Stray image points are most often caused by reflections off the lens in front of the rotating mirror housing. To determine which image point is the one you must measure, block the beam path between the rotating mirror and the fixed mirror. The relevant image point will disappear.

If the image point that you need to measure is significantly off-center, you can move it by adjusting the angle of the beam splitter.

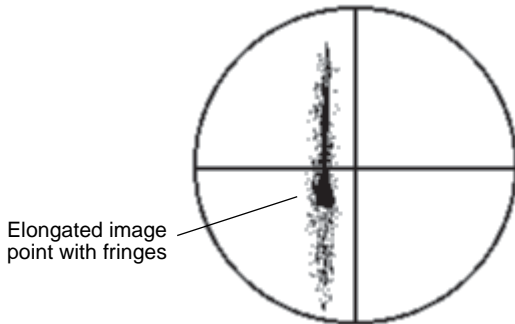

Another common problem is an image that is “stretched” with no easily discernible maxima. Check first to make sure that this is the image that is needed by blocking the beam path between the moving and fixed mirrors. If it is, then twist  $L_2$  slightly until the image coalesces into a single spot.

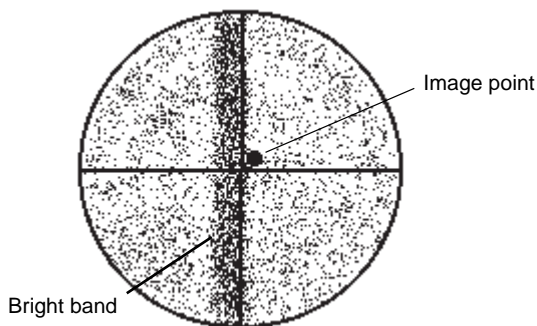

Once the mirror begins to rotate, it is safe to look into the microscope without the polarizers.

With the mirror rotating, you will notice that the carefully aligned pattern has changed: now the entire field is covered with a random interference pattern, and there is a bright band down the center of the field. Ignore the interference pattern; it can't be avoided. The bright band is the image of the laser when, once each rotation, the mirror reflects it into the microscope beam splitter. This is also unavoidable.

The actual image point will probably be just to one side of the bright band. Check for it by blocking and unblocking the beam path between the rotating mirror and fixed mirror and watching to see what disappears.

If everything is aligned *perfectly*, the image point will be hidden by the bright band; in this case, make sure that there is an image point when the rotating mirror is fixed and is reflecting the laser to the fixed mirror. If there is a correct image point under stationary conditions, then mis-align the

fixed mirror  $M_F$  very slightly ( $0.004^\circ$  or less) around the horizontal axis. This will bring the actual image point out from within the bright band.

## Making the Measurement

The speed of light measurement is made by rotating the mirror at a high speed and using the microscope and micrometer to measure the corresponding deflection of the image point away from its position when the rotating mirror was stationary. By rotating the mirror first in one direction, then in the opposite direction, the total beam deflection is doubled, thereby doubling the accuracy of the measurement.

### Important — Protect the Rotating Mirror Assembly

Before using the High Speed Rotating Mirror Controller to make the mirror rotate, be sure that the locking thumbscrew for the rotating mirror is completely loosened so the mirror can rotate freely.

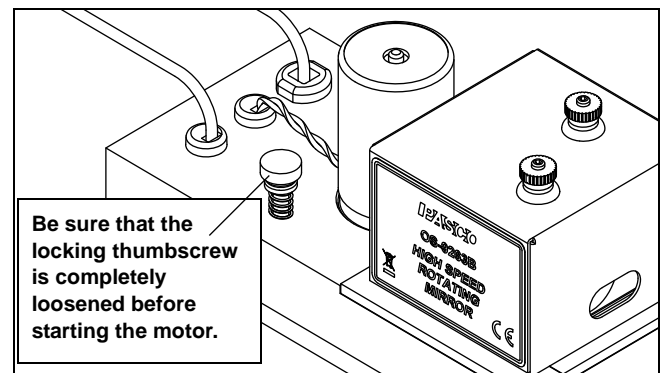

### Important — Protect Your Eyes

Remove the Component Holder with the two Calibrated Polarizers, but do not look into the microscope if the rotating mirror is not rotating. If the mirror is rotating, it is safe to look into the microscope.

### High Speed Rotating Mirror Controller

- If the slide switch on the controller is moved to the ON position, the digital display will show “0” and the green LED next to ‘CW’ will blink.
- When the START/STOP control button is pressed, the rotating mirror starts rotating. The ‘CW’ LED will blink until the mirror reaches 750 revolutions per second, and then the LED will shine continuously. Wait until this happens before adjusting the speed to maximum.
- When the START/STOP control button is pressed and *held*, the yellow LED next to ‘MAX SPEED’ will begin to shine and the digital display will show “1500”. Release the START/STOP control button. The green LED will blink until the mirror speed reaches 1500 revolutions per second and then the green LED will shine continuously.
- Press the START/STOP button again to stop the motor.



## Record Data

- Use the controller to start the mirror rotating in the clockwise (CW) direction at 750 revolutions per second.
- Check that the image point is in sharp focus. Adjust the microscope and  $L_2$  if necessary to improve the image.
- While watching through the microscope, use the controller to increase the speed of rotation to MAX SPEED, and note how the image point deflection increases.
- When the rotation speed stabilizes, turn the micrometer knob on the Measuring Microscope to align the center of the beam image with the cross hair in the microscope that is perpendicular to the direction of deflection.
- Record the micrometer reading as  $s'_{CW}$  (clockwise).
- Use the controller to stop the mirror rotating.
  - CAUTION:** Do not look through the microscope when the laser is on and the mirror is not rotating.
  - NOTE:** When the direction of the micrometer knob is reversed, there will always be some movement of the micrometer knob before the stage responds. This error is small and it can be eliminated. Before reversing the direction of rotation of the mirror, turn the knob slightly to adjust the initial position of the micrometer stage. For the next measurement, turn the micrometer knob in the same direction as you adjusted it.
- Use the DIRECTION control button to select CCW.
- Press the START/STOP controller button to start the mirror rotating in the counterclockwise direction at 750 revolutions per second.
- While watching through the microscope, use the controller to increase the speed of rotation to MAX SPEED, and note now the image point deflects in the opposite direction.
- When the rotation speed stabilizes, turn the micrometer knob to align the center of the beam image with the cross hair in the microscope as before,
- Record the micrometer reading as  $s'_{CCW}$  (counter-clockwise).
- User the controller to stop the mirror rotating.

### NOTES:

- When the mirror is rotated at MAX SPEED, the image point will widen in the direction of displacement. Position the microscope cross-hair in the center of the resulting image.
- The micrometer on the Measuring Microscope is graduated in increments of 0.01 mm for the beam deflections.

The following equation was derived earlier in the manual:

$$c = \frac{4AD^2\omega}{(D+B)\Delta s'} \quad (\text{EQ6})$$

where:

$c$  = the speed of light

$\omega$  = the rotational velocity of the rotating mirror ( $M_R$ )

$A$  = the distance between lens  $L_2$  and lens  $L_1$ , minus the focal length of  $L_1$

$B$  = the distance between lens  $L_2$  and the rotating mirror ( $M_R$ )

$D$  = the distance between the rotating mirror ( $M_R$ ) and the fixed mirror ( $M_F$ )

$\Delta s'$  = the displacement of the image point, as viewed through the microscope. ( $\Delta s' = s_1 - s$ ; where  $s$  is the position of the image point when the rotating mirror ( $M_R$ ) is stationary, and  $s_1$  is the position of the image point when the rotating mirror is rotating with angular velocity  $\omega$ .)

When adjusted to fit the parameters just measured, it becomes:

$$c = \frac{8\pi AD^2((Rev)/s_{CW} + (Rev)/s_{CCW})}{(D+B)(s'_{CW} - s'_{CCW})}$$

Use this equation, along with **Figure 1: Diagram of the Foucault Method**, to calculate  $c$ , the speed of light.

**NOTE:** The following equation is the same as the original equation, EQ6, but with two differences. The rotational speed is expressed in rad/s, and the CCW rotational speed will be a negative number, indicating the direction of rotation.

$$c = \frac{4AD^2(\omega_{CW} - \omega_{CCW})}{(D+B)(s'_{CW} - s'_{CCW})}$$



## Notes on Accuracy and Maintenance

### Accuracy

Precise alignment of the optical components and careful measurement are, of course, essential for an accurate measurement using this equipment. Beyond this, the main factor affecting accuracy is the distance between the fixed and rotating mirrors.

As mentioned in the alignment procedure, the optimum distance between  $M_R$  and  $M_F$  is from 10 to 15 meters. Within this range, accuracy of 5% is readily obtainable. If space is a problem, the distance between the mirrors can be reduced to as little as 1 meter and proportional reduction in accuracy will result.

In general, longer distances provide greater accuracy. The rotating mirror,  $M_R$ , rotates farther as the light travels between the mirrors, and the image deflection is correspondingly greater. Greater deflections reduce the percentage of measurement error.

However, the optical components are designed for optimal focusing of the image point at 13.5 meters (this is the radius of curvature of  $M_F$ ). Image focusing is not a significant problem as long as the distance between the mirrors is within about 15 meters. At larger distances the intensity and focus of the image point begins to drop, and measurement and alignment are hampered.

Typical sample data taken in our lab gives values for  $c$  that are within 1.5 - 2.5% of accepted values.

### Maintenance

Regular maintenance for this equipment is minimal. The mirrors and lenses should be cleaned periodically.

**IMPORTANT:** The lenses may be cleaned with lens tissue, but do not use lens tissue on the spherical mirror ( $M_F$ ). It has a delicate aluminized front surface and should only be cleaned with alcohol and a soft cloth. Do not use any cleaning compound that contains ammonia because the ammonia will attack the aluminum surface.

If problems arise with the rotating mirror assembly, such as a broken drive belt, notify PASCO scientific. We do not recommend that you attempt to fix this equipment yourself. (See the Technical Support information at the end of this manual.)

## Technical Support

For assistance with any PASCO product, contact PASCO at:

Address: PASCO scientific  
10101 Foothills Blvd.  
Roseville, CA 95747-7100

Phone: +1 916-786-3800 (worldwide)  
800-772-8700 (U.S.)

E-mail: support@pasco.com

Web: www.pasco.com

For the latest information about the Complete Speed of Light Apparatus, Basic Speed of Light Apparatus, or High Speed Rotating Mirror, so to the PASCO web site at [www.pasco.com](http://www.pasco.com) and enter the model number in the search window.

**Limited Warranty** For a description of the product warranty, see the PASCO catalog. **Copyright** The PASCO scientific *Instruction Manual* is copyrighted with all rights reserved. Permission is granted to non-profit educational institutions for reproduction of any part of this manual, providing the reproductions are used only in their laboratories and classrooms, and are not sold for profit. Reproduction under any other circumstances, without the written consent of PASCO scientific, is prohibited. **Trademarks** PASCO, PASCO Capstone, PASPORT, SPARK Science Learning System, SPARK SLS, and SPARKvue are trademarks or registered trademarks of PASCO scientific, in the United States and/or in other countries. For more information visit [www.pasco.com/legal](http://www.pasco.com/legal).

### Product End of Life Disposal Instructions:

This electronic product is subject to disposal and recycling regulations that vary by country and region. It is your responsibility to recycle your electronic equipment per your local environmental laws and regulations to ensure that it will be recycled in a manner that protects human health and the environment. To find out where you can drop off your waste equipment for recycling, please contact your local waste recycle/disposal service, or the place where you purchased the product.

The European Union WEEE (Waste Electronic and Electrical Equipment) symbol (to the right) and on the product or its packaging indicates that this product must not be disposed of in a standard waste container.

