

# Time Resolved Spectroscopy: From Molecules to Solid State Materials

H. Volfova<sup>1, a)</sup>, R. Wilcken<sup>1, b)</sup>, M. Block<sup>1, c)</sup> and E. Riedle<sup>1, d)</sup>

<sup>1</sup> *Lehrstuhl für BioMolekulare Optik, Ludwig-Maximilians-Universität (LMU), Oettingenstraße 67, 80538 München, Germany*

Corresponding authors: <sup>a)</sup> Henrieta.Volfova@physik.uni-muenchen.de

<sup>b)</sup> roland.wilcken@physik.uni-muenchen.de

<sup>c)</sup> Matthias.Block@physik.uni-muenchen.de

<sup>d)</sup> riedle@physik.uni-muenchen.de

**Abstract.** Optical spectroscopy is one of the most powerful methods to give a deep understanding of photophysical and photochemical processes in a material. The sub-50 fs broadband transient absorption spectrometer of our own design [1, 2] features fully tunable excitation (from 225 to 1700 nm) and enables us to resolve all relevant processes in the investigated reaction pathways (Fig. 1). The material is firstly excited with a sub-30 fs or ns light pulse. The subsequent sensitive ( $< 20 \mu\text{OD}$ ) broadband probe enables to monitor the photo-induced transmission changes in the time range from femtoseconds to milliseconds

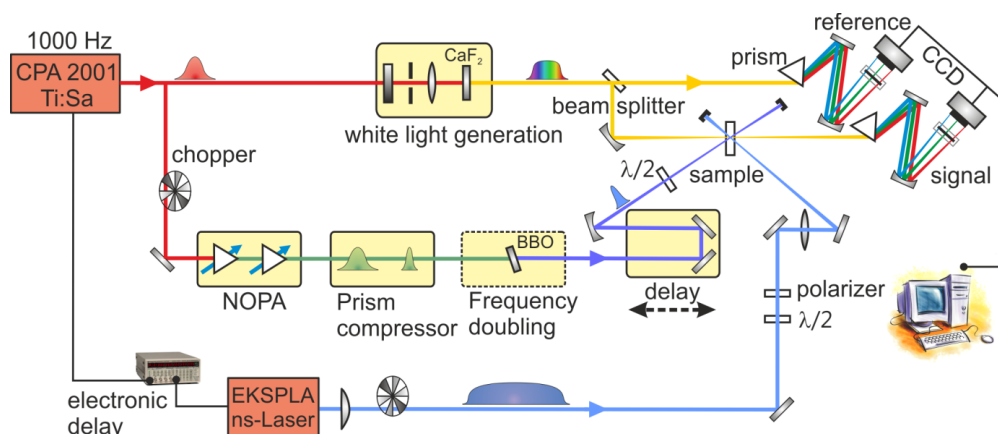

**FIGURE 1.** Transient absorption spectrometer with a pump in the UV/Vis with wavelength tunable fs or ns pulses. The information about the electronically excited states and possible products and the molecular dynamics is probed using a second, white light pulse spanning from 280 to 720 nm or even deeper in the UV range.

The first system discussed in the talk are diarylethene based molecular switches. They undergo the cyclization reaction after UV light irradiation, while the bond cleavage can be initiated by visible light. One of the reasons why this family of materials has attracted so much attention in the last decades, is the combination of an outstanding performance, good thermal stability and most effective optical properties with possible applications in optoelectronics [3], molecular sensors [4] and memory storages [5].

From the category of solid states materials we investigated thin films of cobalt and gold. A very short laser pulse excites the electron gas in the metal. This process is accompanied with the generation of a nonequilibrium in the electronic system. The rapid heating of the film excites longitudinal phonons coherently and the lattice expansion creates a strain wave perpendicular to the film. A detailed analysis of the dynamics shows that the processes depend on the thickness of the film and render the electron-phonon coupling strength.

## References

1. U. Megerle, I. Pugliesi, C. Schrieffer, C. F. Sailer, and E. Riedle, *Appl. Phys. B* 96, 215-231 (2009).
2. E. Riedle, M. Bradler, M. Wenninger, C. F. Sailer, and I. Pugliesi, *Faraday Discuss.* 163, 139-158 (2013).
3. D. Kim, H. Jeong, H. Lee, W-T. Hwang, J. Wolf, E. Scheer, T. Huhn, H. Jeong, and T. Lee, *Advanced Materials* 26, 23, 3968-3973 (2014).
4. J. M. Abendroth, O. S. Bushuyev, P. S. Weiss, and C. J. Barrett, *ACS Nano* 9, 8, 7746-7768 (2015).
5. M. Irie, T. Fukaminato, K. Matsuda, and S. Kobatake, *Chem. Rev.* 114, 24, 12174–12277 (2014).